

Going beyond the limit:
NEW PEC-TA-P

Premium Anchor Channel
PEC-TA-P hot-rolled

Technical Datasheet
December 2020



Selector for premium anchor channels PEC-TA-P hot-rolled

PEC-TA-P hot-rolled anchor channels					
Type		PEC-TA-CE 40/22-P		PEC-TA-CE 50/30-P	
					
Channel bolt type		HBC-40/22	HBC-40/22-N	HBC-50/30	HBC-50/30-N
Channel bolt size		M12-M16	M16	M12-M20	M16-M20
Base material	Cracked concrete	■	■	■	■
	Uncracked concrete	■	■	■	■
	Normal weight concrete (NWC)	■	■	■	■
	Light weight concrete (LWC)	☒	☒	☒	☒
	Reinforced/unreinforced	■	■	■	■
Technical data	European Technical Assessment (ETA)	■	■	■	■
	Static 2D	■	■	■	■
	Static 3D (only HDG)	-	■	-	■
	Seismic	-	-	-	-
	Fatigue (only HDG)	■	-	■	-
Fire	■	-	■	-	
Specification	Hot-dip galvanized (HDG)	■	■	■	■
	Stainless steel A4	■	■	■	■
	Tear-out band	✓	✓	✓	✓
	End caps	✓	✓	✓	✓
PROFIS Anchor Channel software					✓

■ ETA approved ☒ Internal tests

Free Design-Software

For your individual design we suggest to use our comfortable design software. PROFIS Anchor Channel is a reliable planning tool to optimize the design of anchor channels for each specific construction project. A user-friendly interface allows quick and easy selection of suitable anchor channels and bolts for any type of application.

The calculations are based on the current design code EN 1992-4/ EOTA-TR047 and the European Technical Assessment ETA-16/0929.

Benefits









- Fast and efficient planning of fixings with anchor channels
- Clear and concise calculation reports
- Wide range of design parameters
- Functions for automatic planning optimization

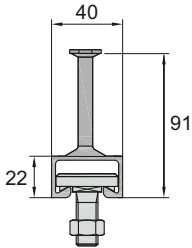
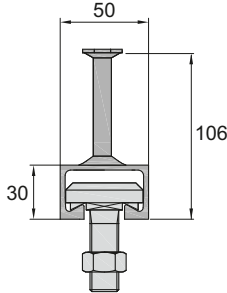
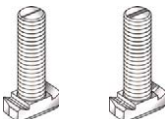
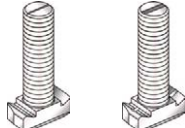

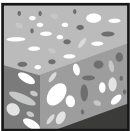
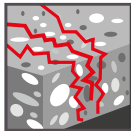
Download PROFIS Anchor Channel Software here:

www.pec-europe.com/en/downloads/software.html

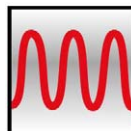
Product overview

Anchor channels PEC-TA-P	
PEC-TA-CE 40/22-P	PEC-TA-CE 50/30-P
	
	
HBC-40/22 and HBC-40/22-N	HBC-50/30 and HBC-50/30-N

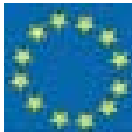
Base material		Load conditions				
						
Concrete (uncracked)	Concrete (cracked)	Static/ quasi-static	Static/ 2D loading	Static/ 3D loading	Fatigue	Fire resistance

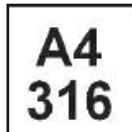
Other Information			
			
European Technical Assessment (ETA)	CE conformity	PROFIS Anchor Channel software	Corrosion resistance

Approvals

Description	Issuing Authority	No.
European Technical Assessment (ETA) covering 2D, 3D static, fatigue and fire loads.	DIBt Berlin	ETA-16/0929

Product features

Premium anchor channel PEC-TA-P hot-rolled

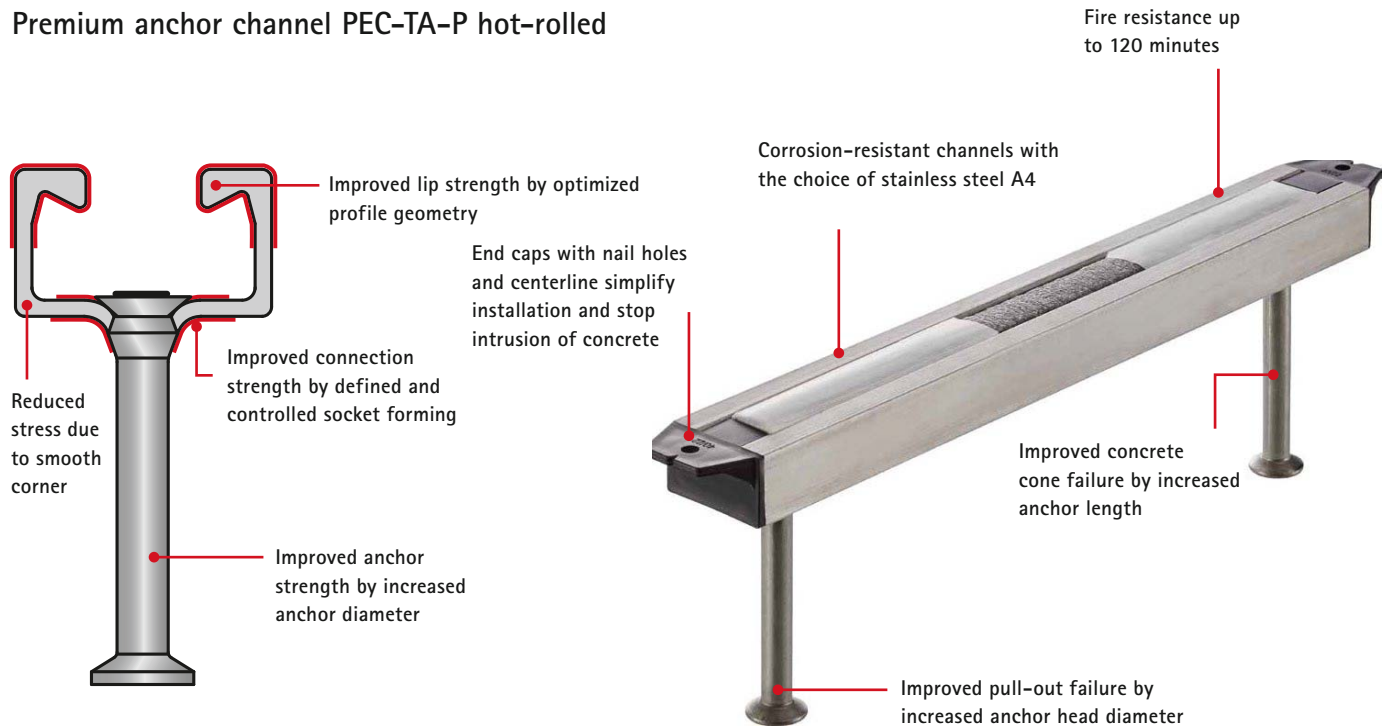

Nomenclature of anchor channels PEC-TA-P hot-rolled

① PEC anchor channel	② Profile type and size	③ Premium channel	④ Material finish	⑤ Foam Filler	⑥ Anchor channel length [mm]
PEC-TA-CE	40/22	P	Hot-dip galvanized (FV) or A4 (stainless steel)	PKF	300

Examples: ① Channel type ② Profile type/size ③ Premium channel ④ Material finish ⑤ Foam Filler ⑥ Length

PEC-TA-CE 40/22-P-FV-PKF-0300



Channel dimensions hot-rolled profiles

Anchor channel	b_{ch}	h_{ch}	t_{nom}	d_{ch}	f	I_y
	[mm]					[mm ⁴]
PEC-TA-CE 40/22-P	40.1	23.0	2.7	18.0	6.0	21.504
PEC-TA-CE 50/30-P	49.6	30.0	3.2	22.5	8.1	57.781

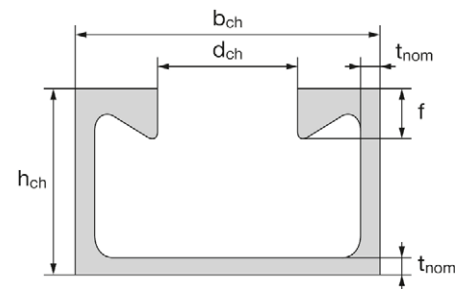

Anchor dimensions (welded I-anchor or round anchor)

Anchor channel	I-anchor ¹⁾						Round anchor					
	min l_a	t_w	b_h	t_h	w_a	A_h	min l_a	d_a	d_h	t_h	A_h	
	[mm]						[mm ²]	[mm]				[mm ²]
PEC-TA-CE 40/22-P	125.0	6.0	25.0	5.0	20.0	380	70.0	10.0	21.5	2.2	285	
PEC-TA-CE 50/30-P	125.0	6.0	25.0	5.0	25.0	475	78.0	11.0	26.0	2.5	436	

¹⁾ Available on request . Not on stock.

Anchor types

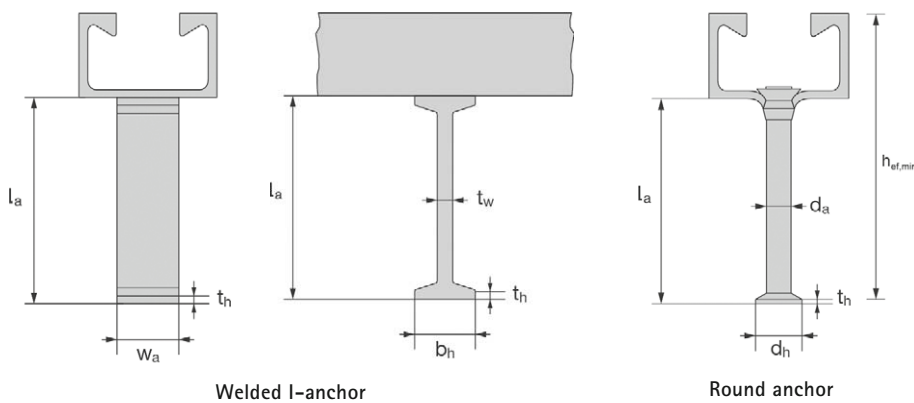

Installation parameters for anchor channels

PEC-TA-CE		40/22-P	50/30-P
Minimum effective embedment depth	$h_{ef,min}$	91	106
Minimum anchor spacing	s_{min}	50 ¹⁾	
Maximum anchor spacing	s_{max}	250	
End spacing	x	25 ²⁾	
Minimum channel length	l_{min}	100	
Minimum edge distance (c_{11} , $c_{1,2}$ & c_{21} , c_{22})	c_{min}	50	75
Minimum thickness of concrete member	h_{min}	100	120

¹⁾ $s_{min} = 100$ mm when used in combination with notched bolts

²⁾ The end spacing may be increased from 25 to 35 mm

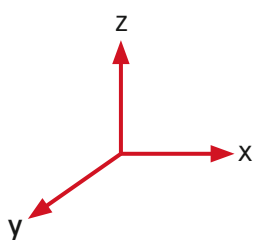

X - Longitudinal shear $-V_x$
Y - Perpendicular shear $-V_y$
Z - Tension $-N$

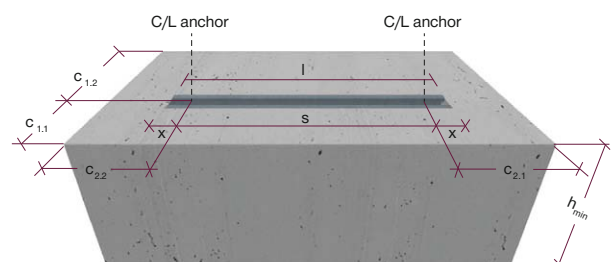

Material of anchor channels and channel bolts

Component	Carbon steel			Stainless steel
	Mechanical properties	Coating		Mechanical properties
1	2a	2b	2c	3
Channel profile	1.0038, 1.0044, 1.0045 according to EN 10025: 2005 1.0976, 1.0979 according to EN 10149: 2013	Hot-dip galvanized $\geq 50 \mu\text{m}$ according to EN ISO 10684: 2004/AC: 2009		1.4362, 1.4401 1.4404, 1.4571, 1.4578 according to EN 10088: 2005
Anchor	1.0038, 1.0213, 1.0214 according to EN 10025: 2005 1.5523, 1.5535 according to EN 10263: 2002-02	-	Hot-dip galvanized $\geq 50 \mu\text{m}$ according to EN ISO 10684: 2004/ AC: 2009	1.4362, 1.4401 1.4404, 1.4571, 1.4578 according to EN 10088: 2005 ³⁾
Channel bolt	Steel grade 4.6 and 8.8 according to EN ISO 898-1: 2013	Electroplated according to EN ISO 4042: 1999	Hot-dip galvanized $\geq 50 \mu\text{m}$ according to EN ISO 10684: 2004/ AC: 2009	Grade 50 or 70 according to EN ISO 3506: 2009
Plain washer ¹⁾ according to ISO 7089: 2000 and ISO 7093-1: 2000	Hardness class A $\geq 200 \text{ HV}$	Electroplated according to EN ISO 4042: 1999	Hot-dip galvanized $\geq 50 \mu\text{m}$ according to EN ISO 10684: 2004/ AC: 2009	1.4401, 1.4404 1.4571, 1.4578 according to EN 10088: 2005
Hexagonal nut according to ISO 4032: 2012 or DIN 934: 1987-10 ²⁾	Property class 5 or 8 according to EN ISO 898-2: 2012	Electroplated according to EN ISO 4042: 1999	Hot-dip galvanized $\geq 50 \mu\text{m}$ according to EN ISO 10684: 2004/ AC: 2009	Property class 50, 70 or 80 according to EN ISO 3506: 2009

¹⁾ In scope of delivery only for notched bolts

²⁾ Hexagonal nuts according to DIN 934 :1987-10 for channel bolts made from carbon steel (4.6) and stainless steel

³⁾ Anchors made of carbon steel according column 2a may also be used if they are welded and their concrete cover is more than 50mm and the tempering colors are removed

Channel bolts nomenclature

① PEC channel bolt	② Bolt type	③ Diameter	④ Bolt length [mm]	⑤ Steel grade	⑥ Finish or material
HBC	40/22	M12	50	8.8 & A4-70	FV (HDG) or A4 (stainless steel)
HBC	40/22-N	M16	60	8.8	FV (HDG)

Examples: ① Channel bolt ② Bolt type ③ Diameter ④ Bolt length ⑤ Steel grade ⑥ Finish or material

HBC-40/22 M12x50 8.8F (standard bolt)

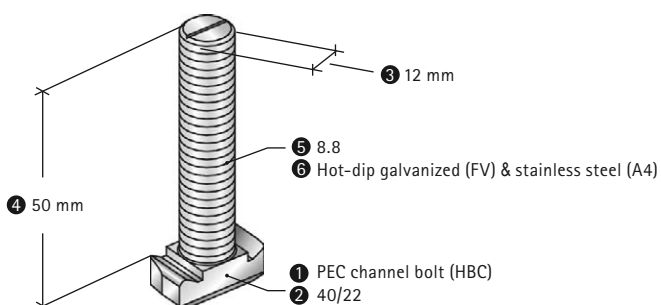

HBC-40/22-N M16x60 8.8F (notched bolt)

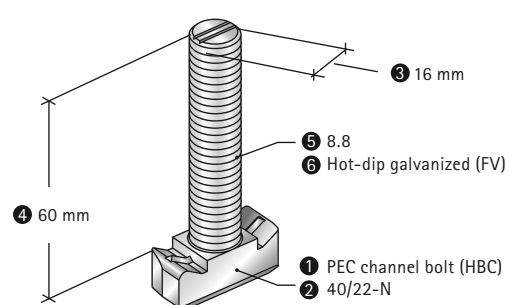

Channel bolt dimensions

Anchor channel	Channel bolt type	Dimensions			
		b_1	b_2	k	d
[mm]					
PEC-TA-CE 40/22-P	HBC-40/22	14.0	33.0	10.5	10
		17.0		11.5	12
	HBC-40/22-N	17.0	33.0	11.5	16
	PEC-TA-CE 50/30-P	HBC-50/30	17.0	42.0	14.5
21.0			15.5		16
HBC-50/30-N		21.0	42.0	15.5	20
					16

Channel bolts marking

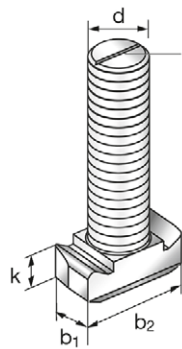

Groove for marking the position of standard bolts

HBC-40/22, HBC-50/30

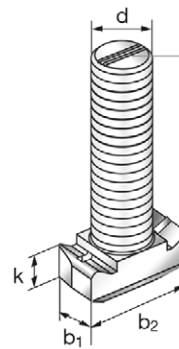

Double groove for marking the position of notched bolts

HBC-40/22-N, HBC-50/30-N

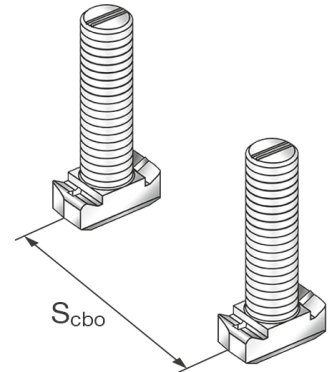

Minimum spacing for channel bolts

Channel bolt	M10	M12	M16	M20		
Minimum spacing between channel bolts	$s_{cbo, min}$	[mm]	50	60	80	100

s_{cbo} = center to center spacing between channel bolts ($s_{cbo, min} = 5d$)

Steel grade and corrosion protection

Channel bolt	Carbon steel ¹⁾		Stainless steel ¹⁾	
Steel grade	4.6	8.8	A4-50	A4-70
f_{uk} [N/mm ²]	400	800 / 830 ²⁾	500	700
f_{yk} [N/mm ²]	240	640 / 660 ²⁾	210	450
Corrosion protection	G ³⁾ F ⁴⁾		R ⁵⁾	

¹⁾ Material properties according to table on page 7

²⁾ Material properties according to EN ISO 898-1 :2013

³⁾ Electroplated

⁴⁾ Hot-dip galvanized



⁵⁾ Stainless steel

Steel resistance values – static resistance under tension, perpendicular shear and longitudinal shear load



Static/
quasi-static

Steel resistance values under tension load – anchor channel

PEC-TA-CE			40/22-P	50/30-P
Steel failure: Failure of anchor				
	Characteristic resistance	$N_{Rk,s,a}$ [kN]	40.0	57.0
	Design resistance	$N_{Rd,s,a}$ [kN]	22.2	31.7
Steel failure: Failure of connection between anchor and channel				
	Characteristic resistance	$N_{Rk,s,c}$ [kN]	39.6	50.6
	Design resistance	$N_{Rd,s,c}$ [kN]	22.0	28.1
Steel failure: Local failure by flexure of channel lips				
	Characteristic or design spacing of the channel bolts	$s_{l,N}$ [mm]	79.0	98.0
	Characteristic resistance	$N^0_{Rk,s,l}$ [kN]	47.9	50.5
	Design resistance	$N^0_{Rd,s,l}$ [kN]	26.6	28.1

Steel resistance values under tension load – channel

PEC-TA-CE		40/22-P	50/30-P	
Steel failure: Failure by flexure of channel				
	Characteristic flexural resistance	$M_{Rk,s,flex}$ [Nm]	1704	3448
	Design flexural resistance	$M_{Rd,s,flex}$ [Nm]	1482	2998

Displacements under tension load

PEC-TA-CE		40/22-P	50/30-P
Tension load	N [kN]	15.3	25.8
Short-term displacement ¹⁾	δ_{N0} [mm]	1.1	1.4
Long-term displacement ¹⁾	$\delta_{N\infty}$ [mm]	2.2	2.8

¹⁾ Displacements in midspan of the anchor channel, including slip of channel bolt, deformation of channel lips, bending of the channel and slip of the anchor channel in concrete



Static/
quasi-static





Steel resistance values under perpendicular and longitudinal shear load – anchor channel

PEC-TA-CE		40/22-P		50/30-P	
Steel failure: Failure of anchor					
	Characteristic resistance	$V_{Rk,s,a,y}$ [kN]	58.1	100.0	
		$V_{Rk,s,a,x}$ [kN]	24.0	34.2	
	Design resistance	$V_{Rd,s,a,y}$ [kN]	38.7	66.7	
		$V_{Rd,s,a,x}$ [kN]	16.0	22.8	
Steel failure: Failure of connection between anchor and channel					
	Characteristic resistance	$V_{Rk,s,c,y}$ [kN]	58.1	100.0	
		$V_{Rk,s,c,x}$ [kN]	23.8	30.4	
	Design resistance	$V_{Rd,s,c,y}$ [kN]	32.3	55.6	
		$V_{Rd,s,c,x}$ [kN]	13.2	16.9	
Steel failure: Local failure by flexure of channel lips					
	Characteristic or design spacing of the channel bolts for shear	$s_{l,v}$ [mm]	80.0	99.0	
	Characteristic resistance	$V_{Rk,s,l,y}^0$ [kN]	55.0	91.7	
	Design resistance	$V_{Rd,s,l,y}^0$ [kN]	30.6	50.9	

Steel resistance values under perpendicular shear load in direction of the longitudinal axis of the channel – anchor channel

PEC-TA-CE		40/22-P		50/30-P	
Steel failure: Connection between channel lips and channel bolt					
Characteristic resistance	$V_{Rk,s,l,x}^0$ [kN]	HBC-40/22-N M16 8.8F	12,5	-	
		HBC-50/30-N M16 8.8F	-	8.3	
		HBC-50/30-N M20 8.8F		8.3	
Design resistance	$V_{Rd,s,l,x}^0$ [kN]	HBC-40/22-N M16 8.8F	5.0	-	
		HBC-50/30-N M16 8.8F	-	4.6	
		HBC-50/30-N M20 8.8F	-	4.6	

Steel resistance values under tension and perpendicular shear load – channel bolts

HBC channel bolt diameter				M10	M12	M16	M20		
Steel failure									
	Characteristic tension resistance	$N_{Rk,s}$ [kN]	HBC-40/22	4.6	23.2	-			
				8.8	-	67.4	125.6	-	
				A4-70	20.5	59.0	91.0		
			HBC-40/22-N	8.8	-	-	125.6	-	
			HBC-50/30	4.6	-				
				8.8	-	67.4	125.6	147.1	
	A4-70	-		59.0	109.9	121.2			
	HBC-50/30-N	8.8	-	-	125.6	186.6			
		Design tension resistance	$N_{Rd,s}$ [kN]	HBC-40/22	4.6	11.6	-	-	
					8.8	-	44.9	83.7	-
					A4-70	10.9	31.6	48.7	-
				HBC-40/22-N	8.8	-	-	83.7	-
HBC-50/30				4.6	-				
				8.8	-	44.9	83.7	98.1	
		A4-70	-	31.6	58.8	64.8			
HBC-50/30-N		8.8	-	-	83.7	124.4			
		Characteristic shear resistance	$V_{Rk,s}$ [kN]	HBC-40/22	4.6	13.9	-		
					8.8	23.2	33.7	62.8	-
					A4-70	24.4	35.4	65.9	
				HBC-40/22-N	8.8	-	-	62.8	-
	HBC-50/30			4.6	-				
				8.8	-	33.7	62.8	101.7	
		A4-70	-	35.4	65.9	102.9			
	HBC-50/30-N	8.8	-	-	62.8	101.7			
		Design shear resistance	$V_{Rd,s}$ [kN]	HBC-40/22	4.6	8.3	-		
					8.8	18.6	26.9	50.2	-
					A4-70	15.6	22.7	42.2	
				HBC-40/22-N	8.8	-	-	50.2	-
HBC-50/30				4.6	-				
				8.8	-	26.9	50.2	81.4	
		A4-70	-	22.7	42.2	65.9			
HBC-50/30-N		8.8	-	-	50.2	81.4			



Static/
quasi-static

Steel resistance values under perpendicular shear load with lever arm – channel bolts

HBC channel			M10	M12	M16	M20		
Steel failure								
	Characteristic flexural resistance	$M^{0}_{Rk,s}$ [Nm]	HBC-40/22(-N)	4.6	29.9 ¹⁾	-		
			HBC-50/30(-N)	8.8	59.8	104.8	266.4	538.7
			A4-70	52.3	91.7	233.1	454.4	
	Design flexural resistance	$M^{0}_{Rd,s}$ [Nm]	HBC-40/22(-N)	4.6	17.9 ¹⁾	-		
			HBC-50/30(-N)	8.8	47.8	83.8	213.1	430.9
			A4-70	33.5	58.8	149.4	291.3	
Internal lever arm	a [mm]	HBC-40/22(-N)	40/22	24.3	25.7	27.3		
		HBC-50/30(-N)	50/30	-	29.9	31.7	33.9	

¹⁾ Not applicable for HBC-50/30

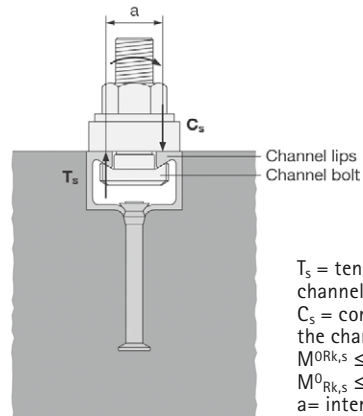

T_s = tension force acting on the channel lips
 C_s = compression force acting on the channel lips
 $M^{0}_{Rk,s} \leq 0.5 \cdot N_{Rk,s,1} \cdot a$
 $M^{0}_{Rk,s} \leq 0.5 \cdot N_{Rk,s} \cdot a$
 a = internal lever arm

Displacements under perpendicular shear load

PEC-TA-CE		40/22-P	50/30-P
Shear load	V_y [kN]	29.0	39.7
Short-term displacement ¹⁾	$\delta_{v0,y}$ [mm]	2.0	2.7
Long-term displacement ¹⁾	$\delta_{v\infty,y}$ [mm]	3.5	4.0
Shear load	V_x [kN]	5.2	3.3
Short-term displacement ¹⁾	$\delta_{v0,x}$ [mm]	0.1	0.1
Long-term displacement ¹⁾	$\delta_{v\infty,x}$ [mm]	0.2	0.2

¹⁾ Displacements in midspan of the anchor channel, including slip of channel bolt, deformation of channel lips and slip of the anchor channel in concrete

Concrete resistance values under static tension and perpendicular shear loads



Static/
quasi-static

Concrete resistance values under tension load – anchor channel

PEC-TA-CE			40/22-P		50/30-P	
Type of anchor (I-Anchor or R-Round Anchor)			I	R	I	R
Pullout failure						
	Characteristic resistance in cracked concrete C12/15	$N_{Rk,p}$ [kN]	34.2	25.6	42.8	39.2
	Characteristic resistance in uncracked concrete C12/15		47.9	35.8	59.9	54.9
	Design resistance in cracked concrete C12/15	$N_{Rd,p}$ [kN]	22.8	17.1	28.5	26.1
	Design resistance in uncracked concrete C12/15		31.9	23.9	39.9	36.6
	Amplification factor for other concrete grades	Ψ_c	$\Psi_c = \frac{f_{c,specified}}{12 \text{ (MPa)}}$			
Concrete cone failure						
	Product factor k_1 for characteristic resistance	cracked concrete	$k_{cr,N}$	8.0	8.2	
		uncracked concrete	$k_{ucr,N}$	11.5	11.7	
Splitting						
	Characteristic edge distance	$c_{cr,sp}$ [mm]	273		318	
	Characteristic spacing	$s_{cr,sp}$ [mm]	$2.0 \cdot c_{cr,sp}$			

Concrete resistance values under perpendicular shear load – anchor channel

PEC-TA-CE			40/22-P		50/30-P	
Pry out failure						
	Product factor	k_B	2.0			
Concrete edge failure						
	Product factor k_{12} for characteristic resistance	cracked concrete	$k_{cr,V}$	7.5		
		uncracked concrete	$k_{ucr,V}$	10.5		

Interaction factors for combined tension and shear loads

PEC-TA-CE		40/22-P		50/30-P	
Steel failure: Local failure by flexure of channel lips and failure by flexure of channel					
Product factor	k_{13}	1.0 ¹⁾			
Steel failure: Failure of anchor and connection between anchor and channel					
Product factor	k_{14}	1.0 ²⁾			

¹⁾ k_{13} can be taken as 2.0 if $V_{Rd,s,l}$ is limited to $N_{Rd,s,l}$

²⁾ k_{14} can be taken as 2.0 if $\max(V_{Rd,s,a}; V_{Rd,s,c})$ is limited to $\min(N_{Rd,s,a}; N_{Rd,s,c})$

Fire resistance

Steel resistance values under fire exposure, tension and perpendicular shear load



Fire resistance

Channel bolt diameter				M10	M12	≥ M16
Steel failure of anchor, connection between anchor and channel, local flexure of channel lip						
Characteristic and design resistance in cracked concrete C20/25	PEC-TA-CE 40/22-P	R60	$N_{Rk,s,fi}$ = $V_{Rk,s,fi}$ or $N_{Rd,s,fi}$ = $V_{Rd,s,fi}$	[kN]	1.7	3.5
		R90			1.2	2.2
		R120			0.9	1.5
	PEC-TA-CE 50/30-P	R60	-	3.8	3.9	
		R90	-	2.5	2.9	
		R120	-	1.9	2.4	

Minimum axis distance of reinforcement

PEC-TA-CE		40/22-P	50/30-P
Min axis distance	R60	35	50
	R90	45	
	R120	55	

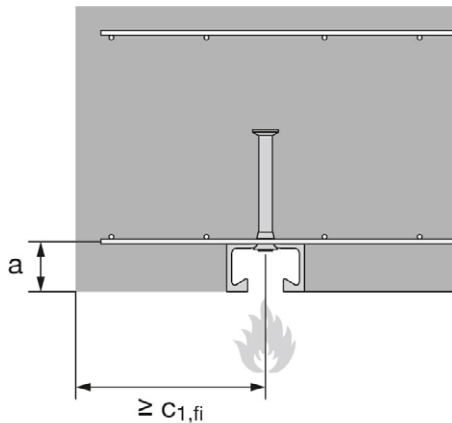

Fire exposure from one side only
 $c_{1,fi} = 2 \times h_{ef}$

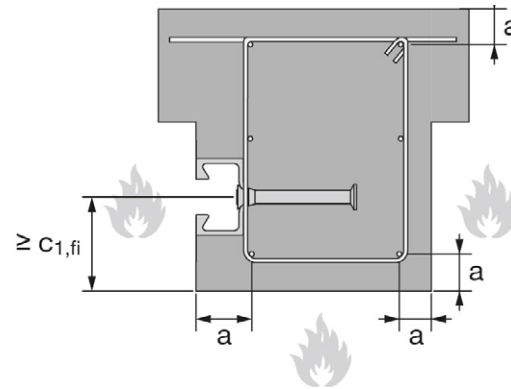

Fire exposure from more than one side
 $c_{1,fi} = \max(2 \times h_{ef}; 300\text{mm})$

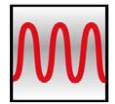

Fatigue

Combination of anchor channels and channel bolts under fatigue tension load

PEC-TA-CE			Channel bolt			
Anchor channel	Anchor type	Corrosion protection	Channel bolt	Diameter	Steel grade	Corrosion protection
PEC-TA-CE 40/22-P	R	F	HBC-40/22	M12	8.8	G F
PEC-TA-CE 50/30-P				M16		
			HBC-50/30	M20		

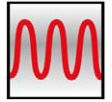

Fatigue

Resistance values under fatigue tension load – steel failure after n load cycles without static preload ($N_{Ed} = 0$) (Design method I according to EOTA TR 050)

PEC-TA-CE		40/22-P	50/30-P
Steel failure	n	$\Delta N_{Rk,s,0,n}$ [kN]	
Characteristic resistance under fatigue tension load after n load cycles without static preload ($N_{Ed} = 0$)	$\leq 10^4$	16.4	20.9
	$\leq 10^5$	7.7	9.0
	$\leq 10^6$	3.2	4.2
	$\leq 2 \cdot 10^6$	2.6	3.7
	$\leq 5 \cdot 10^6$	2.2	3.4
	$\leq 10^8$	2.0	3.3
	$> 10^8$	1.8	3.2

Reduction factor $\eta_{c,fat}$ of characteristic fatigue resistance – concrete failure after n load cycles without static preload ($N_{Ed} = 0$) (Design method I according to EOTA TR 050)

PEC-TA-CE		40/22-P	50/30-P
Pull-out and concrete cone failure	n	$\eta_{c,fat}$ [-]	
Reduction factor after n load cycles without static preload ($N_{Ed} = 0$) for:	$\leq 10^4$	0.736	
	$\leq 10^5$	0.665	
$\Delta N_{Rk,p,0,n} = \eta_{c,fat} \cdot N_{Rk,p}$	$\leq 10^6$	0.600	
$\Delta N_{Rk,c,0,n} = \eta_{c,fat} \cdot N_{Rk,c}$	$\leq 2 \cdot 10^6$	0.582	
	$\leq 5 \cdot 10^6$	0.559	
with $N_{Rk,p}$ calculated according to page 12 and $N_{Rk,c}$ calculated according to EOTA TR047, March 2018 or EN 1992-4: 2018	$\leq 6 \cdot 10^7$	0.500	
	$> 6 \cdot 10^7$	0.500	

Resistance values under fatigue tension load – steel failure with $n \rightarrow \infty$ load cycles without static preload ($N_{Ed} = 0$) (Design method II according to EOTA TR 050)

PEC-TA-CE		40/22-P	50/30-P
Steel failure		$\Delta N_{Rk,s,0'}^{\infty}$ [kN]	
Characteristic fatigue limit resistance ($n \rightarrow \infty$) without static preload ($N_{Ed} = 0$)		1.8	3.2

Reduction factor $\eta_{c,fat}$ of characteristic fatigue limit resistance – concrete failure with $n \rightarrow \infty$ load cycles without static preload ($N_{Ed} = 0$) (Design method II according to EOTA TR 050)

PEC-TA-CE	40/22-P	50/30-P	52/34-P
Pull-out and concrete cone failure	$\eta_{c,fat}$ [-]		
Reduction factor for fatigue limit resistance ($n \rightarrow \infty$) without static preload ($N_{Ed} = 0$) for: $\Delta N_{Rk,p,0,n} = \eta_{c,fat} \cdot N_{Rk,p}$ $\Delta N_{Rk,c,0,n} = \eta_{c,fat} \cdot N_{Rk,c}$ with $N_{Rk,p}$ calculated according to page 13 and $N_{Rk,c}$ calculated according to EOTA TR047, March 2018 or EN 1992-4: 2018	0.5		

Determination of required T-Bolt length

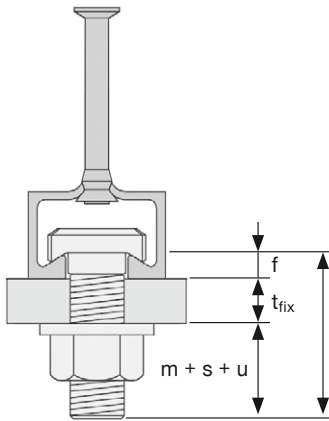

Required T-Bolt length $l = t_{fix} + f + (m+s+u)$

Profile	Height of channel lip (f) [mm]	T-Bolt type	m+s+u [mm]			
			M10	M12	M16	M20
PEC-TA-CE 40/22-P	6	HBC-40/22	13.9	17.3	21.8	-
PEC-TA-CE 40/22-P	6	HBC-40/22-N	-	-	21.8	-
PEC-TA-CE 50/30-P	8	HBC-50/30	-	17.3	21.8	27.0
PEC-TA-CE 50/30-P	8	HBC-50/30-N	-	-	21.8	27.0

l = nominal length of channel bolt
 t_{fix} = fastenable thickness (Thickness of the attached part)
 f = height of channel lip
 m = thickness of the nut (ISO 4032)
 s = thickness of the washer
 u = channel bolt projection
Note: Round the bolt length to the nearest standard channel bolt length.

Installation instructions

Installation instructions for anchor channels PEC-TA-P hot-rolled

1) Correct selection of anchor channel in accordance with the design specification.

2) If cutting of the anchor channel is necessary, cut the channel with an end spacing

$x = 25$ or 35 mm for round or welded anchors with profile:

PEC-TA-CE 40/22-P

PEC-TA-CE 50/30-P

Minimum two anchors per channel!

3) Position the anchor channel such that the channel lips will be flush with the surface of the concrete. Secure anchor channels to formwork (3a) or adjoining reinforcing steel (3b) with nails, staples, rivets, or wire ties as appropriate. Supports and attachments shall be adequate to ensure that anchor channels remain in position during concrete pouring. Anchor channels shall not be pushed into fresh concrete (3c). Anchors shall not be bent, cut or otherwise modified (3d).

4) Anchor channels shall be protected from intrusion of concrete and slurry into the channel during concrete pouring. Place and consolidate concrete around anchor channels to mitigate voids.

Make sure that channels are leveled.

5) Installed anchor channels must be flush with the concrete surface.

6 and 7) Remove the foam filler after hardening of concrete and striking the formwork.

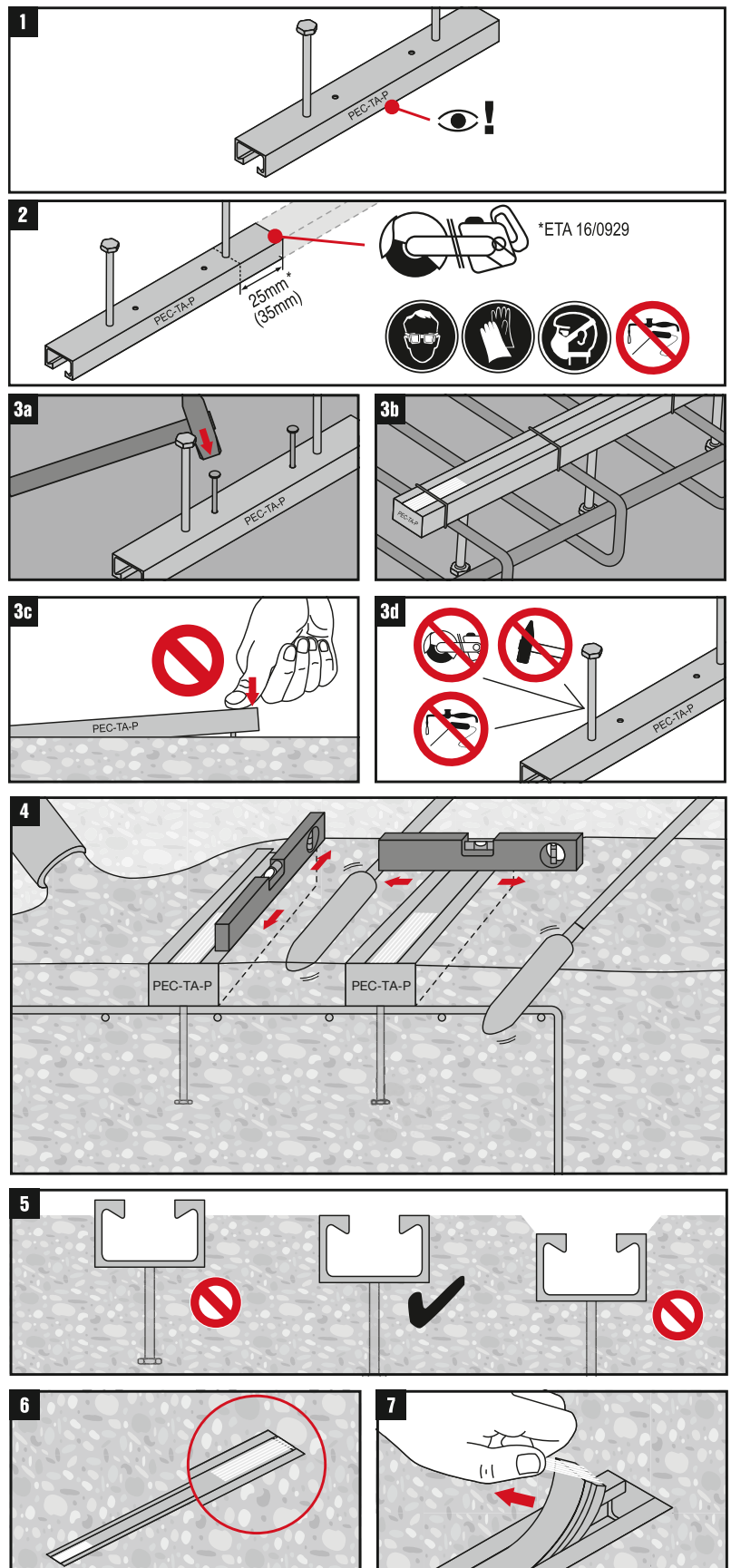

Installation instructions for HBC channel bolts

1) Select PEC channel bolt type HBC in accordance with the design specification.

2) Place the channel bolt in the channel and lock the channel bolt in the channel by turning it 90 degrees.

3) Verify alignment of the bolt with the groove.

4) Verify that the channel bolt is not located outside of that portion of the channel bounded by the outermost anchors.

5) Do not cut channel bolts.



6) Install the fixture distinguishing between installation type A and installation type B.

- For installation type A the fixture is in contact with the concrete surface and the channel profile.
- For installation type B the fixture is not in contact with the concrete surface. The fixture is fastened to the anchor channel by suitable steel element e.g. square plate washer is used to avoid introducing forces into the concrete during application of the installation torque T_{inst} . The steel element shall have a sufficient stiffness to avoid deformation of the channel lips

7) Apply the installation torque T_{inst} to the channel bolt with a calibrated torque wrench. Do not exceed the value T_{inst} distinguishing between installation type A and installation type B.

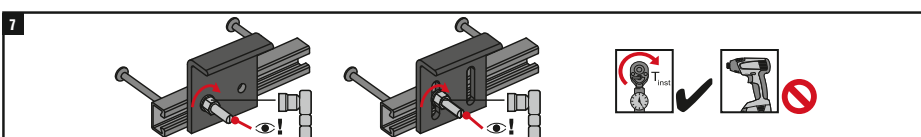
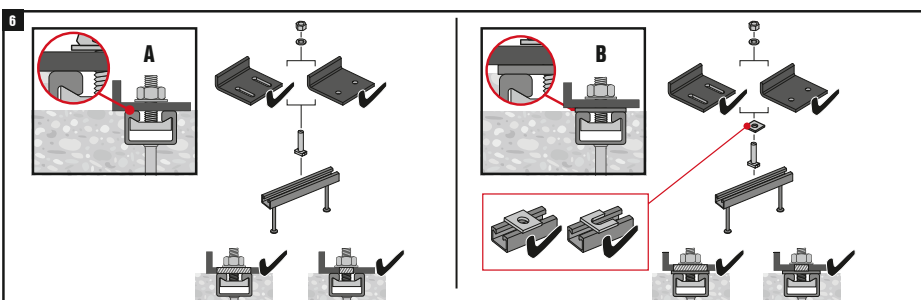
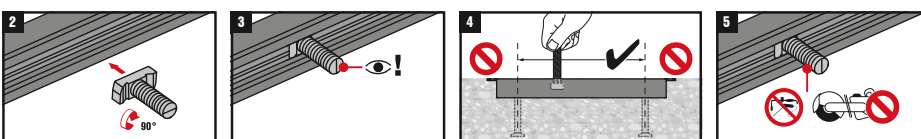
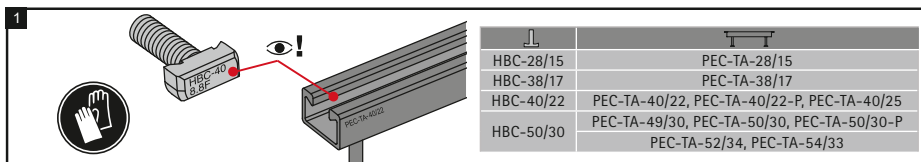
Select the correct installation torque T_{inst} according to material, channel type, channel bolt diameter, and installation type.



Channel bolt		T_{inst} (Nm) ¹⁾				
						
		4.6, 8.8, A4-50, A4-70	4.6	8.8	A4-50	A4-70
HBC-28/15	M8	7	-	20	7	15
	M10	10	-	40	-	30
	M12	13	-	60	-	50
HBC-38/17	M10	15	13	15	-	22
	M12	25	-	45	-	50
	M16	40	-	100	-	90
HBC-40/22	M10	15	13	15	-	22
	M12	25	-	45	-	50
	M16	30	-	100	-	90
HBC-50/30	M12	25	-	45	-	50
	M16	55	-	100	-	130
	M20	55	-	360	-	250

¹⁾ T_{inst} must not be exceeded

Installation instructions for HBC-N channel bolts

1) Select PEC channel bolt type HBC in accordance with the design specification.

2) Place the channel bolt in the channel and lock the channel bolt in the channel by turning it 90 degrees.

HBC-40/22-N	PEC-TA-40/22, PEC-TA-40/22-P
HBC-50/30-N	PEC-TA-50/30, PEC-TA-50/30-P, PEC-TA-52/34

3) Verify alignment of the bolt with the groove.

4) Verify that the channel bolt is not located outside of that portion of the channel bounded by the outermost anchors.

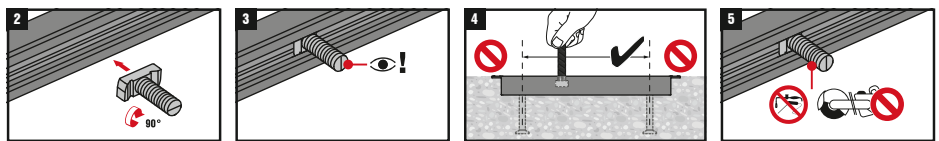

5) Do not cut channel bolts.

6) Install the fixture distinguishing between installation type A and installation type B.

- For installation type A the fixture is in contact with the concrete surface and the channel profile.
- For installation type B the fixture is not in contact with the concrete surface. The fixture is fastened to the anchor channel by suitable steel element e.g. square plate washer is used to avoid introducing forces into the concrete during application of the installation torque T_{inst} . The steel element shall have a sufficient stiffness to avoid deformation of the channel lips

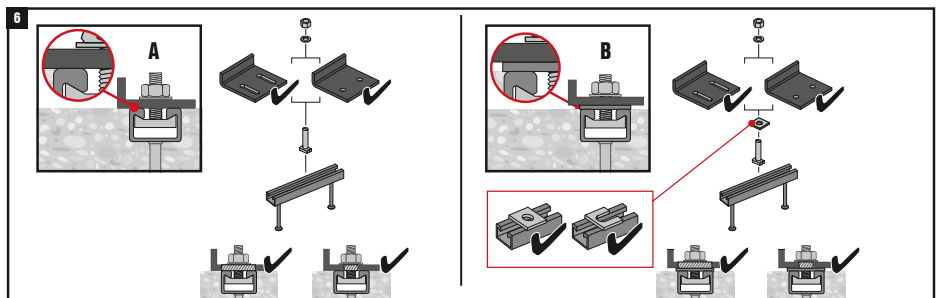

7) Apply the installation torque T_{inst} to the channel bolt with a calibrated torque wrench. Do not exceed the value T_{inst} distinguishing between installation type A and installation type B.

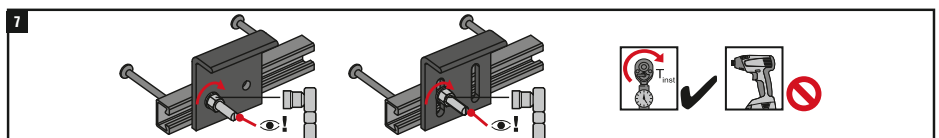

Select the correct installation torque T_{inst} according to material, channel type, channel bolt diameter, and installation type.

Anchor Channel	Channel Bolt	T_{inst} (Nm) ¹⁾	
PEC-TA 40/22-P	HBC-40/22-N M16	8.8	8.8
PEC-TA 40/22		160	160
PEC-TA 40/22		60	160
PEC-TA 50/30-P	HBC-50/30-N M16	185	185
PEC-TA 50/30		185	185
PEC-TA 52/34		185	185
PEC-TA 50/30-P	HBC-50/30-N M20	320	320
PEC-TA 50/30		320	320
PEC-TA 52/34		320	320

¹⁾ T_{inst} must not be exceeded

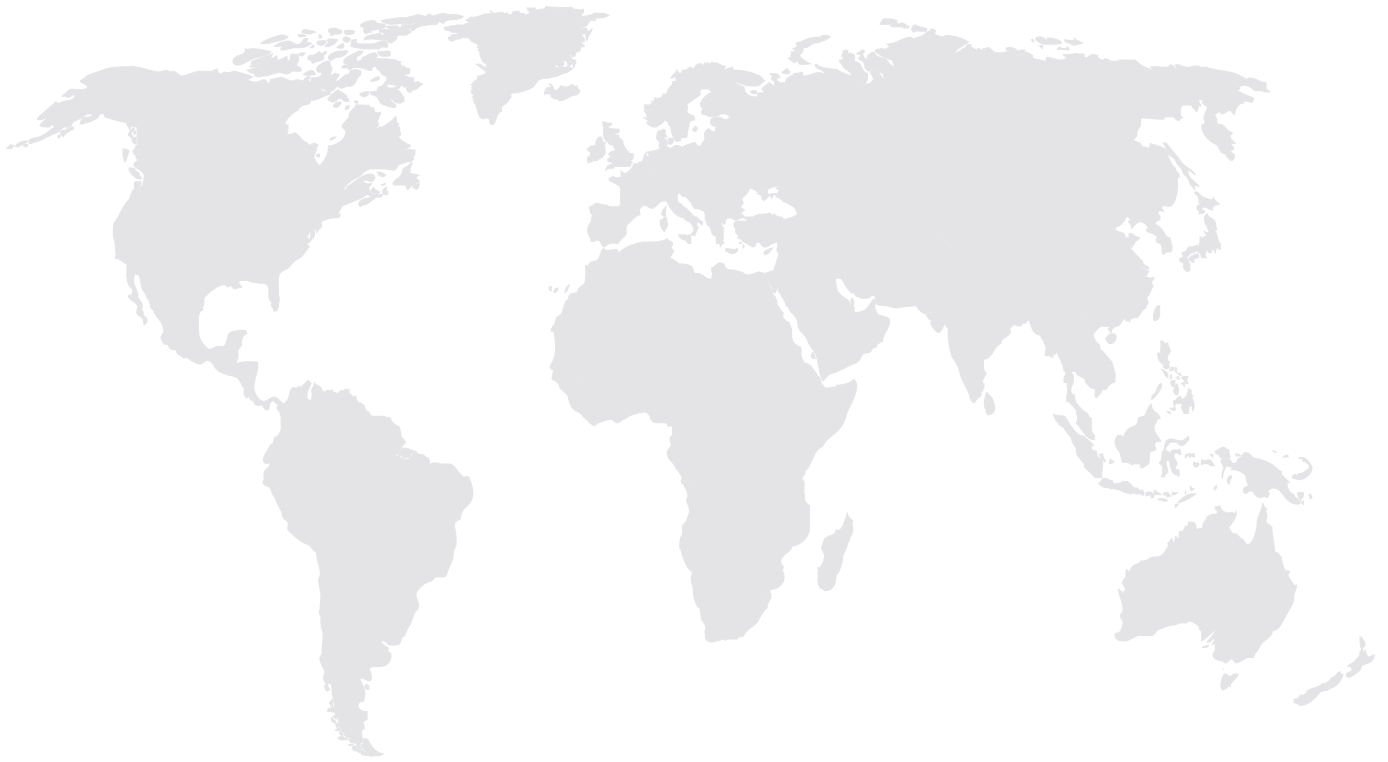

www.pec-europe.com

PEC Europe GmbH

Obere Kaiserswerther Straße 56
47249 Duisburg / Germany
Phone: +49 (0) 203 - 45 65 99 0
Fax: +49 (0) 203 - 45 65 99 25
sales@pec-europe.com

pec EUROPE
*The best of
both worlds!*

For more information, please visit our website at www.pec-europe.com.